

ΗΛΕΚΤΡΙΚΕΣ ΣΥΣΚΕΥΕΣ  
ELECTRIC APPLIANCES

Models: E2-ION16L  
E2-ION20L



Dehumidifier  
**User's Manual**  
Αφυγραντήρας  
**Εγχειρίδιο Χρήστη**

Σας ευχαριστούμε που επιλέξατε τον αφυγραντήρα της INVENTOR. Για τη σωστή χρήση της μονάδας, παρακαλούμε διαβάστε προσεκτικά το παρόν εγχειρίδιο και φυλάξτε το για αναφορά στο μέλλον.

Thank you for choosing INVENTOR dehumidifier. For correct use of this unit, please read this manual carefully and keep it for future reference.



**When using this dehumidifier in the European countries, the following information must be followed:**

**DISPOSAL:** Do not dispose this product as unsorted municipal waste. Separate collection of such waste is necessary for special treatment.

It is prohibited to dispose of this appliance in domestic household waste.

For disposal, there are several possibilities:

- A) The municipality has established collection systems, where electronic waste can be disposed of at least free of charge to the user.
- B) When buying a new product, the retailer will take back the old product at least free of charge.
- C) The manufacture will take back the old appliance for disposal at least free of charge to the user.
- D) As old products contain valuable resources, they can be sold to scrap metal dealers.

Wild disposal of waste in forests and landscapes endangers your health when hazardous substances leak into the ground-water and find their way into the food chain.

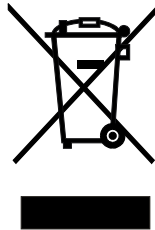

**SAFETY PRECAUTIONS**

Warning .....2  
 Caution .....2  
 Electrical information .....3

**CONTROL PADS ON THE DEHUMIDIFIER**

Control pads.....4  
 Other features.....5

**IDENTIFICATION OF PARTS**

Identification of parts .....6  
 Positioning the unit .....7

**OPERATING THE UNIT**

When using the unit .....7  
 Removing the collected water .....8

**CARE AND MAINTENANCE**

Care and cleaning of the dehumidifier .....9

**TROUBLESHOOTING TIPS**

Troubleshooting tips .....10

**Read This Manual**

Inside you will find many helpful hints on how to use and maintain your dehumidifier properly. Just a little preventive care on your part can save you a great deal of time and money over the life of your dehumidifier. You'll find many answers to common problems in the chart of Troubleshooting Tips. If you review our chart of Troubleshooting Tips first, you may not need to call for service at all.



**⚠ CAUTION**

- This appliance can be used by children aged from 8 years and above and persons with reduced physical, sensory or mental capabilities or lack of experience and knowledge if they have been given supervision or instruction concerning use of the appliance in a safe way and understand the hazards involved. Children shall not play with the. Cleaning and user maintenance shall not be made by children without supervision. ( be applicable for the European Countries )
- This appliance is not intended for use by persons (including children) with reduced physical, sensory or mental capabilities or the authorised service technician for repair or maintenance of this unit. lack of experience and knowledge, unless they have been given supervision or instruction concerning use of the appliance by a
- person responsible for their safety. (be applicable for other countries except the European Countries )
- Children should be supervised to ensure that they do not play with the appliance.
- If the supply cord is damaged, it must be replaced by the manufacturer, its service agent or similarly qualified persons in order to avoid a hazard. The appliance shall be installed in accordance with national wiring regulations.
- The appliance with an electric heater shall have at least one meter of space away from any combustible materials. Contact an authorised service technician for repair or maintenance of this unit.



## SAFETY PRECAUTIONS

To prevent injury to the user or other people and property damage, the following instructions must be followed. Incorrect operation due to ignoring of instructions may cause harm or damage.













- The seriousness is classified by the following indications.

 <b>WARNING</b>	This symbol indicates the possibility of death or serious injury.
 <b>CAUTION</b>	This symbol indicates the possibility of injury or damage to property.



- Meanings of symbols used in this manual are as shown below.

	<b>Never do this.</b>
	<b>Always do this.</b>

### WARNING

- |   |  |  |
|---|--|--|
| <p> Do not exceed the rating of the power outlet or connection device.</p> <ul style="list-style-type: none"> <li>Otherwise, it may cause electric shock or fire due to excess heat generation.</li> </ul> | <p> Do not operate or stop the unit by switching on or off the power.</p> <ul style="list-style-type: none"> <li>It may cause electric shock or fire due to heat generation.</li> </ul> | <p> Do not damage or use an unspecified power cord.</p> <ul style="list-style-type: none"> <li>It may cause electric shock or fire.</li> </ul>                          |
| <p> Do not modify the power cord length or share the outlet with other appliances.</p> <ul style="list-style-type: none"> <li>It may cause electric shock or fire due to heat generation.</li> </ul>       | <p> Do not insert or pull out the plug with wet hands.</p> <ul style="list-style-type: none"> <li>It may cause electric shock.</li> </ul>   | <p> Do not place the unit near a heat source.</p> <ul style="list-style-type: none"> <li>Plastic parts may melt and cause a fire.</li> </ul>                            |
| <p> Disconnect the power if strange sounds, smell, or smoke comes from it.</p> <ul style="list-style-type: none"> <li>It may cause fire and electric shock.</li> </ul>                                     | <p> You should never try to take apart or repair the unit by yourself.</p> <ul style="list-style-type: none"> <li>It may cause failure of the machine or electric shock.</li> </ul>     | <p> Before cleaning, turn off the power and unplug the unit.</p> <ul style="list-style-type: none"> <li>It may cause electrical shock or injury.</li> </ul>             |
| <p> Do not use the machine near flammable gas or combustibles, such as gasoline, benzene, thinner, etc.</p> <ul style="list-style-type: none"> <li>It may cause an explosion or fire.</li> </ul>         | <p> Do not drink or use the water drained from the unit.</p> <ul style="list-style-type: none"> <li>It contains contaminants and could make you sick.</li> </ul>                      | <p> Do not take the water bucket out during operation.</p> <ul style="list-style-type: none"> <li>The water from the full bucket may cause electric shock.</li> </ul> |









### CAUTION

- |   |  |  |
|---|--|--|
| <p> Do not use the unit in small spaces.</p> <ul style="list-style-type: none"> <li>Lack of ventilation can cause overheating and fire.</li> </ul> | <p> Do not put in places where water may splash onto the unit.</p> <ul style="list-style-type: none"> <li>Water may enter the unit and degrade the insulation. It may cause an electric shock or fire.</li> </ul> | <p> Place the unit on a level, sturdy section of the floor.</p> <ul style="list-style-type: none"> <li>If the unit falls over, it may cause water to spill and damage belongings, or cause electrical shock or fire.</li> </ul> |
|---|--|--|

2

## SAFETY PRECAUTIONS

### CAUTION

- |   |  |  |
|---|--|--|
| <p> Do not cover the intake or exhaust openings with cloths or towels.</p> <ul style="list-style-type: none"> <li>A lack of air flow can lead to overheating and fire.</li> </ul>  | <p> Care should be taken when using the unit in a room with the following persons:</p> <ul style="list-style-type: none"> <li>Infants, children, elderly people, and people not sensitive to humidity.</li> </ul>             | <p> Do not use in areas where chemicals are handled.</p> <ul style="list-style-type: none"> <li>This will cause the unit to deteriorate due to chemicals and solvents dissolved in the air.</li> </ul>                      |
| <p> Never insert your finger or other foreign objects into grills or openings. Take special care to warn children of these dangers.</p> <ul style="list-style-type: none"> <li>It may cause electric shock or failure of appliance.</li> </ul> | <p> Do not place heavy objects on the power cord and take care so that the cord is not compressed.</p> <ul style="list-style-type: none"> <li>There is danger of fire or electric shock.</li> </ul>                           | <p> Do not climb up on or sit on the unit.</p> <ul style="list-style-type: none"> <li>You may be injured if you fall or if the unit falls over.</li> </ul>  |
| <p> Always insert the filters securely. Clean filter once every two weeks.</p> <ul style="list-style-type: none"> <li>Operation without filters may cause failure.</li> </ul>  | <p> If water enters the unit, turn the unit off and disconnect the power, contact a qualified service technician.</p> <ul style="list-style-type: none"> <li>It may cause failure of the appliance or an accident.</li> </ul> | <p> Do not place flower vases or other water containers on top of the unit.</p> <ul style="list-style-type: none"> <li>Water may spill inside the unit, causing insulation failure and electrical shock or fire.</li> </ul> |

## Electrical Information

- The manufacturer's nameplate is located on the rear panel of the unit and contains electrical and other technical data specific to this unit.
- Be sure the unit is properly grounded. To minimize shock and fire hazards, proper grounding is important. The power cord is equipped with a three-prong grounding plug for protection against shock hazards.
- Your unit must be used in a properly grounded wall receptacle. If the wall receptacle you intend to use is not adequately grounded or protected by a time delay fuse or circuit breaker, have a qualified electrician install the proper receptacle.
- Ensure the receptacle is accessible after the unit installation.
- Do not use extension cords or adapter plugs with this unit. However, if it is necessary to use an extension cord, use an approved Dehumidifier extension cord only (available at most local hardware stores).
- To avoid the possibility of personal injury, always disconnect the power supply to the unit, before installing and/or servicing.

3

## CONTROL PADS ON THE DEHUMIDIFIER

**NOTE:** The control panel of the unit you purchased may be slightly different according to the models.

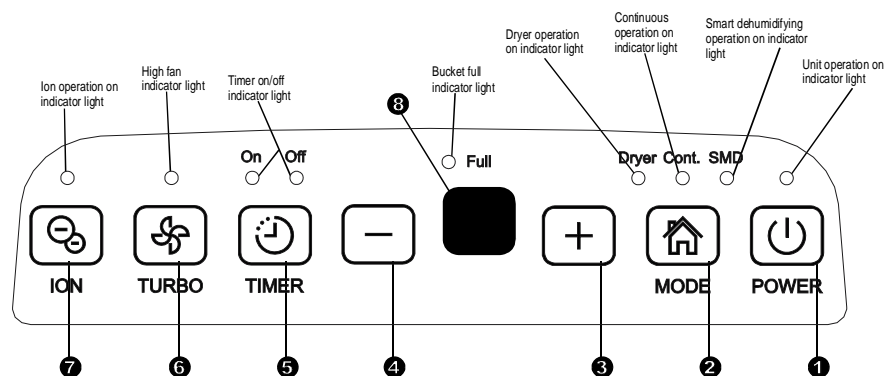

Fig.1

### Control pads

When you push the button to change operation modes, the unit will make a beep sound to indicate that it is changing modes.

#### 1 Power Pad

Press to turn the dehumidifier on and off.

NOTE: When the compressor startups or stops running, the unit may make a loud voice, it is normal.

#### 2 Mode Pad

Press to select the desired operation mode from Dehumidifying, Dryer, Continuous dehumidifying and Smart dehumidifying.

NOTE: Dryer and Smart dehumidifying modes are optional.

#### 3 4 +/− : Down/Up Pads

##### • Humidity Set Control Pads

The humidity level can be set within a range of 35%RH(Relative Humidity) to 85%RH(Relative Humidity) in 5% increments.

For drier air, press the − pad and set to a lower percent value(%).

For damper air, press the + pad and set to a higher percent value(%).

##### • TIMER Set Control Pads

Use the Up/Down pads to set the Auto start and Auto stop time from 0.0 to 24.

#### 5 Timer Pad

Press to initiate the Auto start and Auto stop feature, in conjunction with the + and − key pads.

#### 6 Turbo Pad

Control the fan speed. Press to select either High or Normal fan speed. Set the fan control to High for maximum moisture removal. When the humidity has been reduced and quiet operation is preferred, set the fan control to Normal.

#### 7 Ion Pad(optional)

Press to activate the ionizer. Anions are automatically generated by ionization. The anions deactivate the airborne chemical vapors and dust particles. Press it again to stop the function.

4

## CONTROL PADS ON THE DEHUMIDIFIER

### 8 Display

Shows the set %humidity level from 35% to 85% or auto start/stop time (0-24) while setting, then shows the actual (5% accuracy) room %humidity level in a range of ± 30% RH(Relative Humidity) to 90%RH(Relative Humidity).

#### Error Codes and Protection Codes:

**AS-** Humidity sensor error--Unplug the unit and plug it back in. If error repeats, call for service.

**ES-** Temperature sensor error-- Unplug the unit and plug it back in. If error repeats, call for service.

**P1** - Unit is defrosting-- Allow the unit time to automatically defrost. The protection will clear after the unit self defrosts.

**P2** - Bucket is full or bucket is not in the right position-- Empty the bucket and replace it in the right position.

**E3** - Unit malfunction-- Unplug the unit and plug it back in. If error repeats, call for service.

**EC** - Refrigerant leakage detection-- With this new technology, the display area will appear "EC" when the unit detects refrigerant leakage, call for service.

### Other features

#### Bucket Full Light

Glows when the bucket is ready to be emptied, or when the bucket is removed or not replaced in the proper position.

#### Auto Shut Off

The dehumidifier shuts off when the bucket is full, or when the bucket is removed or not replaced in the proper position. When the set humidity level is reached, the unit will be shut off automatically. For some models, the fan motor will continue operating.

#### Auto Defrost

When frost builds up on the evaporator coils, the compressor will cycle off and the fan will continue to run until the frost disappears.

NOTE: When Auto Defrost is operating, the unit may make a noise of the refrigerant flowing, it is normal.

#### Wait 3 minutes before resuming operation

After the unit has stopped, it will not restart operation for three minutes. This is to protect the unit. Operation will automatically start after 3 minutes.

#### Smart dehumidifying mode(optional)

In smart dehumidifying mode, the unit will automatically control the room humidity in a comfortable range 45%~55% according to the room temperature. The humidity setting function will be invalid.

### Auto-Restart

If the unit turns off unexpectedly due to a power outage, it will restart with the previously set functions automatically when the power resumes.

### Setting the Timer

- When the unit is on, first press the Timer button, the Timer Off indicator light illuminates. It indicates the Auto Stop program is initiated. Press it again and the Time On indicator light illuminates. It indicates the Auto Start is initiated.
- When the unit is off, first press the Timer button, the TIMER ON indicator light illuminates. It indicates the Auto Start program is initiated. Press it again and the Time Off indicator light illuminates. It indicates the Auto Stop is initiated.
- Press or hold the UP or DOWN pad to change the Auto time by 0.5 hour increments, up to 10 hours, then at 1 hour increments up to 24 hours. The control will count down the time remaining until start.
- The selected time will register in 5 seconds and the system will automatically revert back to display the previous humidity setting.
- When the Auto start & Auto stop times are set, within the same program sequence, TIMER ON OFF indicator lights illuminate identifying both ON and OFF times are now programmed.
- Turning the unit ON or OFF at any time or adjusting the timer setting to 0.0 will cancel the Auto Start/Stop function.
- When the LED display window displays the code of P2, the Auto Start/Stop function will also be cancelled.

5

## IDENTIFICATION OF PARTS

### Dryer mode(optional)

The unit can make the MAX dehumidification function when it is under the Dryer mode. The fan speed is fixed at high fan speed. The humidity level is automatically controlled according to the actual room humidity. The unit will quit dryer mode after a maximum 10 hours' operation.

#### NOTE

- The Dryer mode must be operated in a closed room, do not open any doors or windows.
  - To make the best effective dehumidification, please first dehydrate the wet clothes.
  - Make sure to direct the airflow at the wet clothes (See Fig.A).
  - Thick and heavy wet clothes may not get the best effective dehumidification.
- CAUTION**
- Do not cover the air outlet of the unit with clothes. It may cause excessive heat, fire or failure of the unit.
  - Do not place the wet clothes on the top of the unit and do not allow make the water to drip into the. It may cause electric shock, fire or failure of the unit.

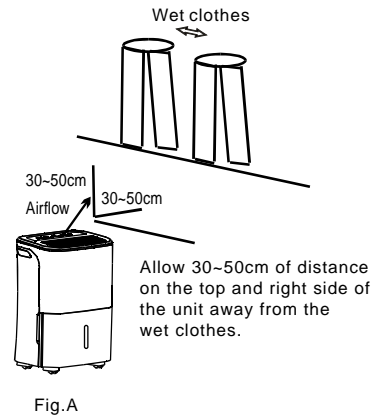

Fig.A

### Identification of parts

#### Front

- 1 Control panel
- 2 Handle (both sides)
- 3 Air outlet grille
- 4 Water bucket
- 5 Water level window

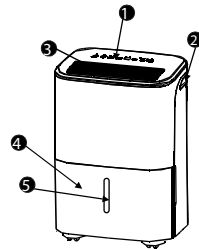

Fig.2

#### Rear

- 1 Drain hose outlet
- 2 Caster
- 3 Power Cord and plug
- 4 Air intake grille
- 5 Air filter (behind the grill)
- 6 Power cord Buckle(Used only when storing the unit.)

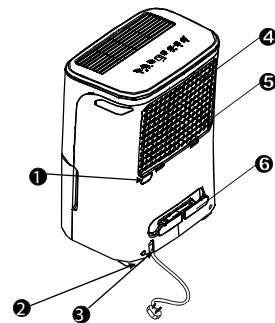

Fig.3

NOTE: All the pictures in the manual are for explanation purposes only. The actual shape of the unit you purchased may be slightly different, but the operations and functions are the same.

6

## OPERATING THE UNIT

### Positioning the unit

A dehumidifier operating in a basement will have little or no effect in drying an adjacent enclosed storage area, such as a closet, unless there is adequate circulation of air in and out of the area.

- Do not use outdoors.
- This dehumidifier is intended for indoor residential applications only. This dehumidifier should not be used for commercial or industrial applications.
- Place the dehumidifier on a smooth, level floor strong enough to support the unit with a full bucket of water.
- Allow at least 20cm of air space on all sides of the unit for good air circulation.
- Place the unit in an area where the temperature will not fall below 5°C(41°F). The coils can become covered with frost at temperatures below 5°C(41°F), which may reduce performance.
- Place the unit away from the clothes dryer, heater or radiator.
- Use the unit anywhere books or valuables are stored to prevent moisture damage.
- Use the dehumidifier in a basement to help prevent moisture damage.
- The dehumidifier must be operated in an enclosed area to be most effective.
- Close all doors, windows and other outside openings to the room.

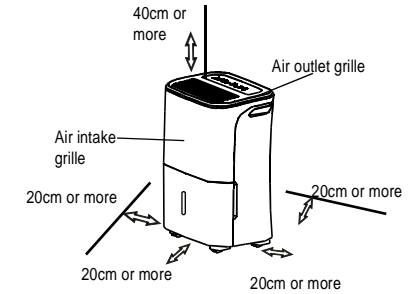

Fig.4a

#### Casters(At four points on the bottom of unit)

- Casters can move freely.
- Do not force casters to move over carpet, nor move the unit with water in the bucket. (The unit may tip over and spill water.)

### When using the unit

- When first using the dehumidifier, operate the unit continuously for 24 hours.
  - This unit is designed to operate with a working environment between 5°C/41°F and 35°C/95°F.
  - If the unit has been switched off and needs to be switched on again quickly, allow approximately three minutes for the correct operation to resume.
  - Do not connect the dehumidifier to a multiple socket outlet, which is also being used for other electrical appliances.
  - Select a suitable location, making sure you have easy access to an electrical outlet.
  - Plug the unit into a electrical socket-outlet with earth connection.
  - Make sure the water bucket is correctly fitted otherwise the unit will not operate properly.
- NOTE: When the water in the bucket reaches to a certain level, please be careful moving the unit to avoid it from falling down

7

## OPERATING THE UNIT

### Removing the collected water

#### There are two ways to remove collected water.

##### 1. Use the bucket

- When the unit is off, if the bucket is full, the unit will beep 8 times and the Full indicator light will flash, the digital display shows P2.
- When the unit is on, if the bucket is full, the compressor turns off and the fan turns off after 30 seconds for drying the water of the condenser, then the unit will beep 8 times and the Full indicator light will flash, the digital display shows P2.
- Slowly pull out the bucket. Grip the left and right handles securely, and carefully pull out straight so the water does not spill. Do not put the tank on the floor because the bottom of the bucket is uneven. Doing so will cause the bucket to fall and the water to spill.
- Throw away the water and replace the bucket. The bucket must be in place and securely seated for the dehumidifier to operate.
- The machine will re-start when the bucket is restored in its correct position.

#### NOTES:

- When you remove the bucket, do not touch any parts inside of the unit. Doing so may damage the product.
- Be sure to push the bucket gently all the way into the unit. Banging the bucket against anything or failing to push it in securely may cause the unit not to operate.
- When you remove the bucket, if there is some water in the unit you must dry it.

##### 2. Continuous draining.

- Water can be automatically emptied into a floor drain by attaching the unit with a water hose (not included).
- Pull the cover down from the back drain hose outlet. Attach a drain hose (ID=13.5mm) and lead it to the floor drain or a suitable drainage facility (see Fig.7).
- Make sure the hose is secure so there are no leaks.
- Direct the hose toward the drain, making sure that there are no kinks that will stop the water flow.
- Place the end of the hose into the drain and make sure the end of the hose is level or sloping downward allowing the water to flow smoothly. Never have the water flow upwards.
- Select the desired humidity setting and fan speed on the unit for continuous draining to start.

NOTE: When the continuous drain feature is not being used, remove the drain hose from the outlet.

1. Pull out the bucket a little.

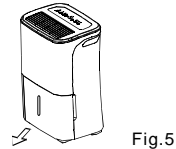

Fig.5

2. Hold both sides of the bucket with even strength, and pull it out from the unit.

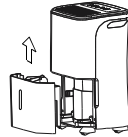
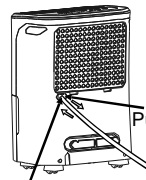

Fig.6

3. Pour the water out.



Pull the cover down

Attach the hose to the drain hose outlet.

Fig.7

## CARE AND MAINTENANCE

### Care and cleaning of the dehumidifier

Turn the dehumidifier off and remove the plug from the wall outlet before cleaning.

#### 1. Clean the Grille and Case

- Use water and a mild detergent. Do not use bleach or abrasives.
- Do not splash water directly onto the main unit. Doing so may cause an electrical shock, cause the insulation to deteriorate, or cause the unit to rust.
- The air intake and outlet grilles get soiled easily, so use a vacuum attachment or brush to clean.

#### 2. Clean the bucket

Every few weeks, clean the bucket to prevent growth of mold, mildew and bacteria. Partially fill the bucket with clean water and add a little mild detergent. Swish it around in the bucket, empty and rinse.

NOTE: Do not use a dishwasher to clean the bucket.

After cleaning, the bucket must be in place and securely seated for the dehumidifier to operate.

#### 3. Clean the air filter

The air filter behind the front grille should be checked and cleaned at least every 30 days or more often if necessary

**NOTE: DO NOT RINSE OR PUT THE FILTER IN AN AUTOMATIC DISHWASHER.**

#### To remove:

- Grip the tab on the filter and pull it upward, then pull it out as shown in Fig.8.
- Clean the filter with warm, soapy water. Rinse and let the filter dry before replacing it. Do not clean the filter in a dishwasher.

#### To attach:

- Insert the air filter into the unit from underside to upside. See Fig.10.

#### CAUTION:

DO NOT operate the dehumidifier without a filter because dirt and lint will clog it and reduce performance.

#### 4. When not using the unit for long time periods

- After turning off the unit, wait one day before emptying the bucket.
- Clean the main unit, water bucket and air filter.
- Cover the unit with a plastic bag.
- Store the unit upright in a dry, well-ventilated place.

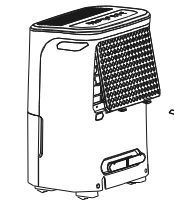

Fig.8

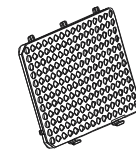

Fig.9

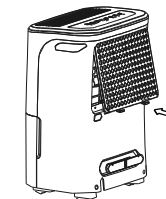

Fig.10

## TROUBLESHOOTING TIPS

Before calling for service, review the chart below.

Problem	What to check
Unit does not start	<ul style="list-style-type: none"> <li>Make sure the dehumidifier's plug is pushed completely into the outlet.</li> <li>Check the house fuse/circuit breaker box.</li> <li>Dehumidifier has reached its preset level or bucket is full.</li> <li>Water bucket is not in the proper position.</li> </ul>
Dehumidifier does not dry the air as it should	<ul style="list-style-type: none"> <li>Did not allow enough time to remove the moisture.</li> <li>Make sure there are no curtains, blinds or furniture blocking the front or back of the dehumidifier.</li> <li>The humidity control may not be set low enough.</li> <li>Check that all doors, windows and other openings are securely closed.</li> <li>Room temperature is too low, below 5°C(41°F).</li> <li>There is a kerosene heater or something giving off water vapor in the room.</li> </ul>
The unit makes a loud noise when operating	<ul style="list-style-type: none"> <li>The air filter is clogged.</li> <li>The unit is tilted instead of upright as it should be.</li> <li>The floor surface is not level.</li> </ul>
Frost appears on the coils	<ul style="list-style-type: none"> <li>This is normal. The dehumidifier has an Auto defrost feature.</li> </ul>
Water on floor	<ul style="list-style-type: none"> <li>Hose to connector or hose connection may be loose.</li> <li>Intended to use the bucket to collect the water, but the back drain plug is removed.</li> </ul>
ES, AS, P1 or P2 appear in the display	<ul style="list-style-type: none"> <li>These are error codes and protection codes. See the CONTROL PADS ON THE DEHUMIDIFIER section.</li> </ul>

Activate your warranty.....  
in **5** simple steps!

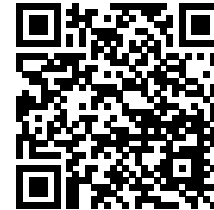

Scan here for the warranty form

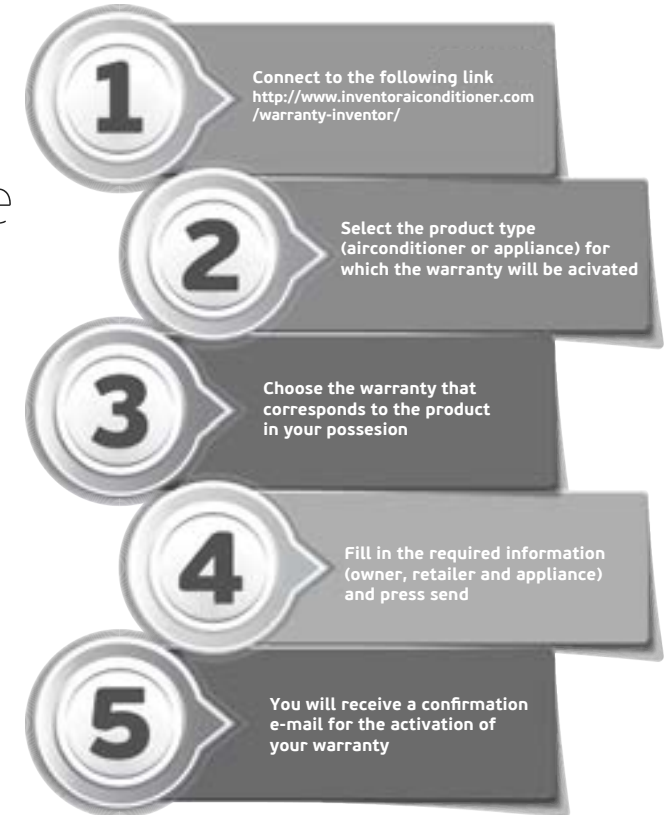

For the electronic warranty submission please type the following link

**<http://www.inventorairconditioner.com/warranty-inventor/>**

## ΓΕΝΙΚΕΣ ΠΑΡΑΤΗΡΗΣΕΙΣ

Για την χρήση του αφυγραντήρα σε χώρες της Ευρωπαϊκής Ένωσης θα πρέπει να ακολουθούνται οι παρακάτω οδηγίες:

**ΑΠΟΡΡΙΨΗ:** Μην απορρίπτετε το συγκεκριμένο προϊόν στα αστικά λύμματα, χρειάζεται ειδική περισυλλογή και επεξεργασία.

Απαγορεύεται η απόρριψη του συγκεκριμένου προϊόντος μαζί με τα αστικά λύμματα.

Για την απόρριψή υπάρχουν αρκετές επιλογές:

A) Έχουν συσταθεί ειδικά συστήματα περισυλλογής ηλεκτρονικών αποβλήτων όπου μπορούν να απορριφθούν χωρίς επιβάρυνση.

B) Κατά την προμήθεια ενός νέου προϊόντος μπορείτε να επιστρέψετε στον προμηθευτή σας το παλιό χωρίς επιβάρυνση.

Γ) Ο κατασκευαστής μπορεί να παραλάβει την παλιά συσκευή προς απόρριψη χωρίς επιβάρυνση

Δ) Μπορούν να πωληθούν σε επαγγελματίες που εκμεταλλεύονται τα μεταλλικά εξαρτήματα των παλιών προϊόντων.

Η απόρριψη σε δάση και πεδιάδες μπορεί να βλάψει την υγεία σας λόγω των επιβλαβών ουσιών που μεταφέρονται μέσω του υδροφόρου ορίζοντα στην τροφική αλυσίδα



## ΠΕΡΙΕΧΟΜΕΝΑ

### ΟΔΗΓΙΕΣ ΑΣΦΑΛΕΙΑΣ

Προειδοποίηση .....	2
Προσοχή .....	2
Ηλεκτρικά χαρακτηριστικά .....	3

### ΠΛΗΚΤΡΑ ΤΟΥ ΑΦΥΓΡΑΝΤΗΡΑ

Πλήκτρα .....	4
Άλλες λειτουργίες .....	5

### ΠΕΡΙΓΡΑΦΗ ΤΩΝ ΕΠΙΜΕΡΟΥΣ ΕΞΑΡΤΗΜΑΤΩΝ

Περιγραφή των επιμέρους εξαρτημάτων .....	6
Τοποθέτηση της μονάδας .....	7

### ΛΕΙΤΟΥΡΓΙΑ ΤΗΣ ΜΟΝΑΔΑΣ

Χρήση της μονάδας .....	7
Αφαίρεση του νερού .....	8

### ΦΡΟΝΤΙΔΑ ΚΑΙ ΣΥΝΤΗΡΗΣΗ

Φροντίδα και καθαρισμός του αφυγραντήρα .....	9
---	---

### ΑΝΤΙΜΕΤΩΠΙΣΗ ΠΡΟΒΛΗΜΑΤΩΝ

Αντιμετώπιση προβλημάτων .....	10
--------------------------------	----

## Διαβάστε το παρόν εγχειρίδιο

Στο παρόν εγχειρίδιο θα βρείτε χρήσιμες συμβουλές για τη σωστή χρήση και συντήρηση του αφυγραντήρα. Η Προληπτική φροντίδα από μέρους σας μπορεί να σας εξοικονομήσει χρόνο και χρήματα και να επιμηκύνει τη ζωή του αφυγραντήρα σας. Θα βρείτε πολλές απαντήσεις σε συνηθή προβλήματα και μπορεί να μην χρειαστεί να επικοινωνήσετε με τεχνικό προσωπικό.



### ⚠ ΠΡΟΣΟΧΗ

- Η συσκευή μπορεί να χρησιμοποιηθεί από παιδιά άνω των 8 ετών και άτομα με ειδικές ανάγκες ή έλλειψη γνώσης μόνο εφόσον επιβλέπονται από άτομα υπεύθυνα για την ασφάλειά τους. Τα παιδιά δεν επιτρέπεται να παίζουν με τη συσκευή. Ο καθαρισμός δεν πρέπει να γίνεται από παιδιά χωρίς επίβλεψη. (Εφαρμογή στις Ευρωπαϊκές χώρες)
- Η συσκευή δεν πρέπει να χρησιμοποιείται από παιδιά και άτομα με ειδικές ανάγκες ή από άτομα με έλλειψη γνώσης ή εμπειρίας, εκτός αν επιβλέπονται από άτομα υπεύθυνα για την ασφάλειά τους (Εφαρμογή σε χώρες εκτός Ευρωπαϊκής Ένωσης).
- Τα παιδιά θα πρέπει να επιβλέπονται ώστε να μην παίζουν με τη μονάδα.
- Εάν φθαρεί το καλώδιο τροφοδοσίας η αντικατάσταση θα πρέπει να γίνει από εξειδικευμένο προσωπικό για την αποφυγή τραυματισμού.
- Η συσκευή θα πρέπει να εγκατασταθεί σύμφωνα με τους εθνικούς κανονισμούς.
- Συσκευή με ηλεκτρική αντίσταση θα πρέπει να τοποθετηθεί τουλάχιστον σε 1m απόσταση από εύφλεκτα υλικά.
- Για την συντήρηση ή επισκευή της συσκευής επικοινωνήστε με εξειδικευμένο προσωπικό.





Για την αποφυγή τραυματισμού και φθοράς της μονάδας θα πρέπει να ακολουθήσετε τις παρακάτω οδηγίες. Η λανθασμένη λειτουργία λόγω αγνόησης των οδηγιών μπορεί να προκαλέσει βλάβη ή ζημιά.

■ Η κατηγοριοποίηση γίνεται σύμφωνα με τις παρακάτω ενδείξεις

 ΠΡΟΕΙΔΟΠΟΙΗΣΗ	Αυτό το σύμβολο υποδεικνύει πιθανότητα θανάτου ή σοβαρού τραυματισμού.
 ΠΡΟΣΟΧΗ	Αυτό το σύμβολο υποδεικνύει την πιθανότητα τραυματισμού ή φθορά της μονάδας.

■ Η σημασία των συμβόλων που εμφανίζονται στο παρόν εγχειρίδιο φαίνονται παρακάτω

 ΠΡΟΕΙΔΟΠΟΙΗΣΗ	Απογορεύεται
 ΠΡΟΣΟΧΗ	Βεβαιωθείτε πως ακολουθείτε τις παρακάτω οδηγίες

 ΠΡΟΕΙΔΟΠΟΙΗΣΗ

 **Συνδέστε σωστά το καλώδιο τροφοδοσίας.**

Σε αντίθετη περίπτωση μπορεί να προκληθεί ηλεκτροπληξία ή πυρκαγιά.

 **Μην τροποποιείτε το μήκος του καλωδίου τροφοδοσίας και μην χρησιμοποιείτε την ίδια πρίζα και για άλλες συσκευές.**

Μπορεί να προκληθεί ηλεκτροπληξία ή πυρκαγιά.

 **Αν ακουστούν περίεργοι θόρυβοι ή αν εξέρχεται κάποια περίεργη οσμή ή καπνός, απενεργοποιήστε αμέσως τη μονάδα και αποσυνδέστε την από την παροχή ρεύματος.**

Μπορεί να προκληθεί ηλεκτροπληξία ή πυρκαγιά.

 **Η μονάδα δεν πρέπει να βρίσκεται κοντά σε εύφλεκτα ή εκρηκτικά αέρια, όπως βενζίνη, διαλυτικά κ.α.**

Μπορεί να προκληθεί έκρηξη ή πυρκαγιά.

 **Μην ενεργοποιείτε ή απενεργοποιείτε τη λειτουργία της μονάδας μέσω του ασφαλειοδιακόπτη.**

Μπορεί να προκληθεί ηλεκτροπληξία ή πυρκαγιά.

 **Μην χρησιμοποιείτε την μονάδα με βρεγμένα χέρια και μην τη λειτουργείτε σε χώρο με υψηλή υγρασία.**

Μπορεί να προκληθεί ηλεκτροπληξία.

 **Μην επιχειρήσετε να επισκευάσετε την μονάδα μόνοι σας.**

Μπορεί να προκληθεί βλάβη ή ηλεκτροπληξία.

 **Μην πίνετε από το νερό που συλλέγεται στη μονάδα.**

Περιέχει συστατικά που μπορεί να βλάψουν την υγεία σας.

 **Μην φθείρετε το καλώδιο ή χρησιμοποιείτε μη προδιαγεγραμμένο καλώδιο.**

Μπορεί να προκληθεί ηλεκτροπληξία ή πυρκαγιά.

 **Μην τοποθετείτε τη μονάδα κοντά σε πηγή θερμότητας.**

Μπορεί να λιώσουν τα πλαστικά μέρη και να προκληθεί πυρκαγιά.

 **Πριν τον καθαρισμό απενεργοποιήστε την μονάδα και αποσυνδέστε την από την παροχή ρεύματος.**

Μπορεί να προκληθεί ηλεκτροπληξία ή τραυματισμός.

 **Μην αφαιρείτε το δοχείο νερού κατά τη λειτουργία της μονάδας.**

Θα ενεργοποιηθεί η αντίστοιχη προστασία και μπορεί να προκληθεί ηλεκτροπληξία.

 ΠΡΟΣΟΧΗ

 **Μην χρησιμοποιείτε τη μονάδα σε μικρούς χώρους.**

Έλλειψη αερισμού μπορεί να προκαλέσει υπερθέρμανση και πυρκαγιά.

 **Μην τοποθετείτε τη μονάδα σε μέρος όπου μπορεί να πέσει πάνω της νερό.**

Μπορεί να εισέλθει νερό και να φθαρεί η μόνωση. Μπορεί να προκληθεί ηλεκτροπληξία ή πυρκαγιά.

 **Τοποθετήστε τη μονάδα σε επίπεδο και σταθερό έδαφος.**

Εάν η μονάδα πέσει μπορεί να βραχούν τα έπιπλα ή να προκληθεί ηλεκτροπληξία ή πυρκαγιά.

 ΠΡΟΣΟΧΗ

 **Μην καλύπτετε τις εισόδους και εξόδους του αέρα.**

Η έλλειψη ροής του αέρα μπορεί να προκαλέσει υπερθέρμανση και πυρκαγιά.

 **Θα πρέπει να δίνεται ιδιαίτερη προσοχή όταν η μονάδα χρησιμοποιείται σε χώρο που υπάρχουν τα παρακάτω άτομα:**

Βρέφη, παιδιά, ηλικιωμένοι και άτομα με ευαισθησία στην υγρασία.

 **Μην χρησιμοποιείτε τη μονάδα σε χώρους όπου υπάρχουν χημικά.**

Θα προκληθεί φθορά στη μονάδα εξαιτίας των χημικών και των διαλυμάτων που υπάρχουν στην ατμόσφαιρα.

 **Μην εισάγετε τα δάχτυλά σας ή άλλα αντικείμενα στα ανοίγματα ή στις περσίδες. Προειδοποιήστε τα παιδιά για αυτούς τους κινδύνους.**

Μπορεί να προκληθεί ηλεκτροπληξία ή δυσλειτουργία της μονάδας.

 **Βεβαιωθείτε πως το καλώδιο τροφοδοσίας δεν συμπιέζεται.**

Υπάρχει κίνδυνος πυρκαγιάς ή ηλεκτροπληξίας.

 **Μην ανεβαίνετε και μην κάθεστε πάνω στη μονάδα.**

Μπορεί να προκληθεί τραυματισμός εάν πέσετε ή εάν πέσει η μονάδα.

 **Να εισάγετε προσεκτικά τα φίλτρα και να τα καθαρίζετε κάθε 15 μέρες.**

Λειτουργία χωρίς φίλτρα μπορεί να προκαλέσει δυσλειτουργία της μονάδας.

 **Εάν εισέλθει νερό στην μονάδα απενεργοποιήστε την, αποσυνδέστε την παροχή ρεύματος και επικοινωνήστε με εξειδικευμένο τεχνικό.**

Υπάρχει κίνδυνος βλάβης της μονάδας ή ατυχήματος.

 **Μην τοποθετείτε βάζα ή άλλα δοχεία με νερό πάνω στη μονάδα.**

Μπορεί να εισέλθει νερό στη μονάδα προκαλώντας φθορά στην μόνωση και ηλεκτροπληξία ή πυρκαγιά.

## Ηλεκτρικά χαρακτηριστικά

- Η πινακίδα που βρίσκεται στο πίσω μέρος της μονάδας περιέχει ηλεκτρικά και άλλα τεχνικά χαρακτηριστικά της μονάδας.
- Βεβαιωθείτε πως η μονάδα είναι σωστά γειωμένη, για την αποφυγή ηλεκτροπληξιών και πυρκαγιών. Το καλώδιο τροφοδοσίας είναι εφοδιασμένο με γείωση για προστασία έναντι ηλεκτροπληξίας.
- Θα πρέπει να χρησιμοποιηθεί πρίζα γειωμένη. Εάν η πρίζα που πρόκειται να χρησιμοποιήσετε δεν είναι κατάλληλη γειωμένη ή προστατευμένη από ασφάλεια ή διακόπτη απευθυνθείτε σε εξειδικευμένο ηλεκτρολόγο για να εγκαταστήσει την κατάλληλη πρίζα.
- Βεβαιωθείτε πως η πρίζα θα είναι προσβάσιμη μετά την εγκατάσταση.
- Μην χρησιμοποιείτε μπαταντζά ή πολύπριζα. Αν όμως χρειαστεί να χρησιμοποιήσετε μπαταντζά, χρησιμοποιήστε μόνο ειδικό καλώδιο για αφυγραντήρα (Διαθέσιμα σε αρκετά καταστήματα)
- Πριν την συντήρηση ή επισκευή να αποσυνδέεται πάντα το καλώδιο τροφοδοσίας για την αποφυγή τραυματισμού.

## ΠΛΗΚΤΡΑ ΠΑΝΩ ΣΤΟΝ ΑΦΥΓΡΑΝΤΗΡΑ

**ΣΗΜΕΙΩΣΗ:** Το πάνελ χειρισμού του αφυγραντήρα που έχετε προμηθευτεί πιθανόν να παρουσιάζει μικρές διαφορές, ανάλογα το μοντέλο.

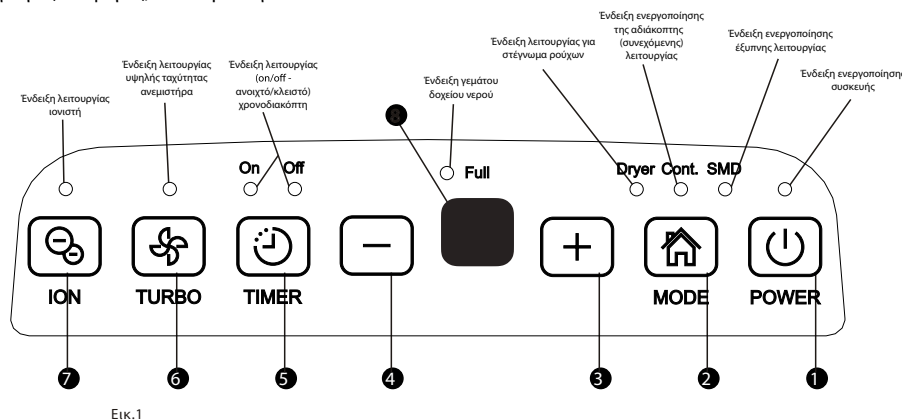

Εικ.1

### Ενδεικτικές λυχνίες

Όταν πατάτε το πλήκτρο για να ενεργοποιήσετε ή να αλλάξετε λειτουργία, ακούγετε ο χαρακτηριστικός ήχος "μπιπ", ως ένδειξη αυτής της αλλαγής.

#### 1 Πλήκτρο Power

Πιέστε το συγκεκριμένο πλήκτρο για να ενεργοποιήσετε και να απενεργοποιήσετε τον αφυγραντήρα.  
ΣΗΜΕΙΩΣΗ: Κατά την εκκίνηση ή την παύση λειτουργίας του συμπιεστή, η μονάδα κάνει ένα δυνατό θόρυβο, ο οποίος είναι φυσιολογικός.

#### 2 Επιλογή λειτουργίας

Πιέστε για να επιλέξετε την επιθυμητή λειτουργία μεταξύ των παρακάτω: Αφύγρανση, Στέγνωμα ρούχων, Αδιάκοπη λειτουργία αφύγρανσης και Εξυπνη αφύγρανση.  
ΣΗΜΕΙΩΣΗ: Οι λειτουργίες Στεγνώματος ρούχων και Εξυπνης αφύγρανσης υπάρχουν σε ορισμένα μοντέλα.

#### 3 4 +/- Πλήκτρα αύξησης / μείωσης

##### • Πλήκτρα ρύθμισης υγρασίας

Το επίπεδο υγρασίας ρυθμίζεται μεταξύ ενός εύρους 35%RH (Σχετική υγρασία) έως 85%RH (Σχετική υγρασία) με απόκλιση 5%.

Για ξηρότερη ατμόσφαιρα πιέστε το πλήκτρο ⊖ ώστε να ρυθμίσετε χαμηλότερο ποσοστό υγρασίας (%).

Για πιο υγρή ατμόσφαιρά, πιέστε το πλήκτρο ⊕ ώστε να ρυθμίσετε υψηλότερο ποσοστό υγρασίας (%).

##### • Πλήκτρα ρύθμισης χρονοδιακόπτη

Χρησιμοποιώντας τα πλήκτρα Up/Down (Επάνω/Κάτω) ενεργοποιείτε την αυτόματη εκκίνηση ή την αυτόματη παύση λειτουργίας της συσκευής από 0.0 έως 24.

#### 5 Πλήκτρο Χρονοδιακόπτη

Το χρησιμοποιείτε για να ρυθμίσετε την Αυτόματη εκκίνηση ή Αυτόματη απενεργοποίηση της συσκευής, σε συνδυασμό με τα πλήκτρα ⊕ και ⊖ .

#### 6 Πλήκτρο Turbo

Έλεγχος της ταχύτητας του ανεμιστήρα. Πιέζετε για να επιλέξετε Υψηλή (High) ή Κανονική (Normal) ταχύτητα ανεμιστήρα. Επιλέγετε την ταχύτητα του ανεμιστήρα στην Υψηλή (High) ταχύτητα όταν θέλετε πιο γρήγορη αφύγρανση. Εφόσον το ποσοστό υγρασίας βελτιωθεί και θέλετε πιο αθόρυβη λειτουργία, επιλέγετε την Κανονική (Normal) ταχύτητα του ανεμιστήρα.

#### 7 Πλήκτρο Ιονιστή (Σε ορισμένα μοντέλα)

Πιέζετε για να ενεργοποιήσετε τον ιονιστή. Τα ανιόντα ενεργοποιούνται αυτόματα από τη λειτουργία ιονισμού. Τα ανιόντα απενεργοποιούν τα χημικά στοιχεία και τα σωματίδια σκόνης που μεταφέρονται στον αέρα. Για επενεργοποίηση πιέζετε ξανά το πλήκτρο.

### 3 Οθόνη

Δείχνει τη ρύθμιση της θερμοκρασίας από 35% έως 85%, ή την ώρα αυτόματης εκκίνησης/παύσης (0-24) την οποία έχετε επιλέξει. Στη συνέχεια δείχνει το επίπεδο υγρασίας του χώρου, (με ακρίβεια + - 5%) μεταξύ του εύρους 35%RH (Σχετική υγρασία) έως 90%RH (Σχετική υγρασία). Κωδικοί βλάβης και προστασίας:

**AS** - Βλάβη στον αισθητήρα υγρασία - Αποσυνδέστε τη συσκευή από το φις της πρίζας και το επανατοποθετείτε. Εάν η βλάβη συνεχίσει καλέστε την τεχνική υποστήριξη.  
**ES** - Βλάβη στον αισθητήρα θερμοκρασίας - Αποσυνδέστε τη συσκευή από το φις της πρίζας και το επανατοποθετείτε. Εάν η βλάβη συνεχίσει καλέστε την τεχνική υποστήριξη.

### Άλλες λειτουργίες

#### Ενδεικτική λυχνία γεμάτου δοχείου

Ανάβει όταν πρέπει να αδειάσετε το δοχείο νερού ή όταν έχει μετακινηθεί το δοχείο ή δεν έχει τοποθετηθεί σωστά.

#### Αυτόματη απενεργοποίηση

Το φλοτέρ απενεργοποιεί τον αφυγραντήρα όταν το δοχείο είναι γεμάτο, έχει μετακινηθεί ή δεν έχει τοποθετηθεί σωστά. Όταν το ποσοστό υγρασίας φτάσει στο επιθυμητό επίπεδο, η μονάδα θα απενεργοποιηθεί αυτόματα.

#### Περιμένετε 3 λεπτά πριν επανεκκινήσετε τον αφυγραντήρα.

Αν απενεργοποιήσετε τον αφυγραντήρα δεν μπορείτε να τον επανεκκινήσετε για τα επόμενα 3 λεπτά. Είναι για την προστασία της μονάδας. Η λειτουργία θα ξεκινήσει αυτόματα μετά από 3 λεπτά.

#### Εξυπνη λειτουργία αφύγρανσης (σε ορισμένα μοντέλα)

Στη λειτουργία εξυπνης αφύγρανσης, η μονάδα ελέγχει αυτόματα τη λειτουργία του δωματίου σε επίπεδα άνεσης από 45% έως 55%, ανάλογα με τη θερμοκρασία του χώρου. Στην περίπτωση αυτή η ρύθμιση υγρασίας που έχετε θέσει δεν θα ισχύει.

## ΠΛΗΚΤΡΑ ΠΑΝΩ ΣΤΟΝ ΑΦΥΓΡΑΝΤΗΡΑ

**P1** - Η συσκευή βρίσκεται σε λειτουργία απόψυξης - Αφήστε τη συσκευή να κάνει αυτόματη απόψυξη. Η ένδειξη θα σβήσει όταν η συσκευή θα έχει τελειώσει την ανάλογη λειτουργία.

**P2** - Το δοχείο είναι γεμάτο ή δεν βρίσκεται στη σωστή θέση - Αδειάστε το δοχείο και τοποθετήστε το και πάλι σε σωστή θέση.

**E3** - Δυσλειτουργία συσκευής - Αποσυνδέστε τη συσκευή από το φις της πρίζας και το επανατοποθετείτε. Εάν η βλάβη συνεχίσει καλέστε την τεχνική υποστήριξη.

**EC** - Διαρροή ψυκτικού υγρού - Με αυτή την καινοτομία, θα εμφανιστεί η ένδειξη "EC" όταν διαπιστωθεί διαρροή ψυκτικού υγρού, οπότε καλέστε την τεχνική υποστήριξη.

### Αυτόματη Επανεκκίνηση

Σε περίπτωση διακοπής ρεύματος, η μονάδα θα επανέλθει σε λειτουργία διατηρώντας τις προηγούμενες ρυθμίσεις.

#### • Ρύθμιση Χρονοδιακόπτη

Όταν η μονάδα είναι σε λειτουργία, πιέστε πρώτα το πλήκτρο Timer, οπότε ανάβει η ένδειξη Timer off, η οποία υποδεικνύει ότι έχει προγραμματιστεί αυτόματη παύση της μονάδας. Εάν το πιέσετε πάλι θα ανάψει η ένδειξη Timer on, η οποία υποδεικνύει ότι έχει προγραμματιστεί αυτόματη εκκίνηση της μονάδας.

• Όταν η μονάδα είναι εκτός λειτουργίας, πιέστε πρώτα το πλήκτρο Timer, οπότε ανάβει η ένδειξη Timer on, η οποία υποδεικνύει ότι έχει προγραμματιστεί αυτόματη εκκίνηση της μονάδας. Εάν το πιέσετε πάλι θα ανάψει η ένδειξη Timer off, η οποία υποδεικνύει ότι έχει προγραμματιστεί αυτόματη παύση της μονάδας.

• Πιέστε ή κρατήστε πατημένο το πλήκτρο UP (επάνω) ή DOWN (κάτω) για να ρυθμίσετε την ώρα του χρονοδιακόπτη με ακρίβεια μισής ώρας, έως 24 ώρες. Ο χρονοδιακόπτης θα μετράει αντίστροφα την ώρα έως την εκκίνηση της συσκευής.

• Η επιλογή ώρας θα αποθηκευτεί εντός 5 δευτερολέπτων και η οθόνη της συσκευής θα γυρίσει αυτόματα στην προηγούμενη ένδειξη ρύθμισης υγρασίας.

• Όταν ρυθμιστεί ο χρόνος αυτόματης εκκίνησης και παύσης, οι αντίστοιχες λυχνίες αναβοσβήνουν ταυτόχρονα, υποδεικνύοντας τον νέο προγραμματισμό εκκίνησης και παύσης της συσκευής.

• Εάν εκκινήσετε ή απενεργοποιήσετε τη συσκευή ή θέσετε τη ρύθμιση του χρονοδιακόπτη στο 0.0, ακυρώνονται όλες οι ρυθμίσεις αυτόματης εκκίνησης ή παύσης.

• Εάν εμφανιστεί στην οθόνη η ένδειξη P2, σημαίνει επίσης ότι η ρύθμιση αυτόματης εκκίνησης/παύσης έχει ακυρωθεί.

## ΠΕΡΙΓΡΑΦΗ ΤΩΝ ΕΠΙΜΕΡΟΥΣ ΕΞΑΡΤΗΜΑΤΩΝ

### Λειτουργία στεγνώματος ρούχων (σε ορισμένες συσκευές)

Η συσκευή μπορεί να λειτουργήσει στο μέγιστο της λειτουργίας αφύγρανσης όταν ρυθμίσετε τη λειτουργία στεγνώματος ρούχων. Ο ανεμιστήρας ρυθμίζεται σε υψηλή ταχύτητα. Το επίπεδο υγρασίας ρυθμίζεται αυτόματα σύμφωνα με το πραγματικό επίπεδο υγρασίας του χώρου. Μετά από συνεχόμενη λειτουργία 10 ωρών στη δεδομένη ρύθμιση, η μονάδα θα ακυρώσει αυτόματα τη λειτουργία στεγνώματος.

Σημείωση:

- Η λειτουργία αυτή θα πρέπει να ρυθμίζεται σε κλειστό χώρο, δεν πρέπει να αφήνετε ανοιχτά πόρτες ή παράθυρα.
- Για να έχετε το καλύτερο δυνατό αποτέλεσμα στραγγίστε τα βρεγμένα ρούχα.
- Στρέψτε τον ανεμιστήρα της συσκευής απ' ευθείας προς τα βρεγμένα ρούχα (εικόνα Α).
- Για βαριά και χοντρά ρούχα πιθανό να μην έχετε το καλύτερο επιθυμητό αποτέλεσμα αφύγρανσης.

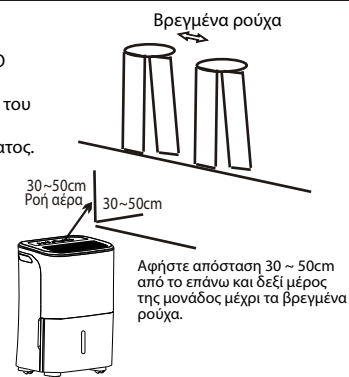

Εικ. Α

### ▲ ΠΡΟΣΟΧΗ

- Μην καλύπτετε την έξοδο του αέρα με ρούχα, μπορεί να προκαλέσει αυξημένη θέρμανση, πυρκαγιά ή βλάβη της συσκευής.
- Μην τοποθετείτε τα βρεγμένα ρούχα πάνω από τη μονάδα, οπότε στάζει νερό επάνω της. Μπορεί να προκληθεί ηλεκτροπληξία, ερπυσμός ή βλάβη της συσκευής.

## Περιγραφή των επιμέρους εξαρτημάτων

### Μπροστινή πλευρά

- 1 Πάνελ χειρισμού
- 2 Λαβή (και από τις 2 πλευρές)
- 3 Πλέγμα εξόδου αέρα
- 4 Δοχείο νερού
- 5 Δείκτης στάθμης νερού

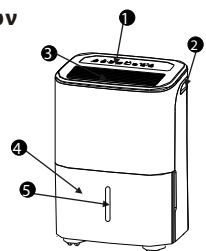

Εικ. 2

### Πίσω πλευρά

- 1 Έξοδος αγωγού αποστράγγισης
- 2 Ροδάκι
- 3 Σημείο πρόσδεσης καλωδίου τροφοδοσίας
- 4 Πλέγμα εισόδου αέρα
- 5 Φίλτρο αέρα (πίσω από το πλέγμα εισόδου αέρα)
- 6 Σημείο πρόσδεσης καλωδίου τροφοδοσίας (Χρησιμοποιείται μόνο όταν θέλετε να αποθηκεύσετε τη μονάδα)

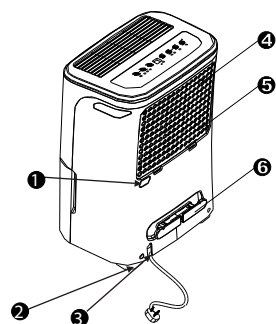

Εικ. 3

ΣΗΜΕΙΩΣΗ: Όλες οι εικόνες στο παρόν εγχειρίδιο είναι αναφορικές. Η μονάδα που έχετε προμηθευτεί μπορεί να διαφέρει. Οι λειτουργίες παραμένουν ίδιες.

6

## ΠΕΡΙΓΡΑΦΗ ΤΩΝ ΕΠΙΜΕΡΟΥΣ ΕΞΑΡΤΗΜΑΤΩΝ

### Τοποθέτηση της μονάδας

Εάν ένας αφυγραντήρας λειτουργεί σε υπόγειο δεν θα μπορεί να αφυγρανεί κάποιο διπλανό χώρο, εκτός αν υπάρχει επαρκής κυκλοφορία του αέρα μέσα και έξω.

- Μην λειτουργείτε τον αφυγραντήρα σε εξωτερικούς χώρους.
- Ο αφυγραντήρας είναι σχεδιασμένος για εσωτερική οικιακή χρήση. Δεν πρέπει να χρησιμοποιείται σε επαγγελματικούς ή βιομηχανικούς χώρους.
- Τοποθετήστε τον αφυγραντήρα σε επίπεδο και σταθερό έδαφος το οποίο μπορεί να αντέξει τη μονάδα με γεμάτο το δοχείο νερού.
- Για την επαρκή κυκλοφορία του αέρα ο ελεύθερος χώρος γύρω από τον αφυγραντήρα πρέπει να είναι τουλάχιστον 20cm.
- Μην τοποθετείτε το αφυγραντήρα σε μέρος όπου η θερμοκρασία μπορεί να πέσει κάτω από τους 5C, διότι μπορεί να σχηματιστεί πάγος στο στοιχείο του και να μειωθεί η απόδοσή του.
- Βεβαιωθείτε πως δεν είναι τοποθετημένος κοντά σε στεγνωτήριο, θερμαντική συσκευή ή καλοριφέρ.
- Μπορείτε να χρησιμοποιήσετε τη μονάδα για να προστατέψετε από την υγρασία βιβλία ή πολύτιμα αντικείμενα.
- Μπορείτε να χρησιμοποιήσετε τον αφυγραντήρα σε υπόγειο για την αποφυγή φθοράς εξαιτίας της υγρασίας.
- Για την καλύτερη απόδοση του αφυγραντήρα θα πρέπει να χρησιμοποιείται σε κλειστός χώρος.
- Κλείστε όλες τις πόρτες, τα παράθυρα ή οποιοδήποτε άλλο άνοιγμα.

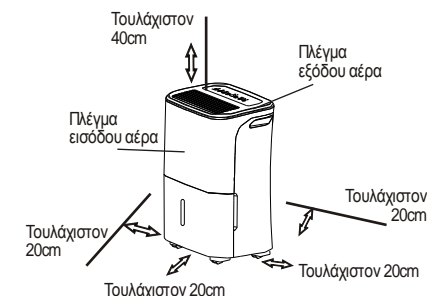

Εικ. 4a

Ροδάκια (Σε τέσσερα σημεία στη βάση της μονάδας)

- Τα ροδάκια μπορούν να κινηθούν ελεύθερα.
- Μην κινείτε τα ροδάκια σε χαλί ή όταν το δοχείο νερού είναι γεμάτο. (Μπορεί να αναποδογυρίσει η μονάδα και να χυθεί το νερό)

### Χρήση της μονάδας

- Κατά την πρώτη λειτουργία της μονάδας, θα πρέπει να την αφήσετε να λειτουργήσει συνεχόμενα για 24 ώρες.
- Η μονάδα είναι σχεδιασμένη να λειτουργεί σε περιβάλλον 5°C με 35°C.
- Εάν έχετε απενεργοποιήσει τη μονάδα και χρειαστεί να την ενεργοποιήσετε αμέσως, αφήστε να περάσουν πρώτα 3 λεπτά.
- Μην συνδέετε τον αφυγραντήρα σε πολύπριζο το οποίο χρησιμοποιείται ήδη για άλλες συσκευές.
- Επιλέξτε μια θέση εύκολα προσβάσιμη.
- Χρησιμοποιήστε πρίζα με γείωση 220-240V, 50Hz (ανατρέξτε στην πινακίδα χαρακτηριστικών που βρίσκεται στο πλαϊνό ή πίσω μέρος της μονάδας)
- Βεβαιωθείτε πως το δοχείο νερού είναι σωστά τοποθετημένο, διότι σε αντίθετη περίπτωση ο αφυγραντήρας δεν θα λειτουργεί ομαλά.

ΣΗΜΕΙΩΣΗ: Όταν το νερό δοχείο νερού είναι σχετικά γεμάτο, παρακαλώ προσέξτε τις μετακινήσεις της συσκευής προς αποφυγή ανατροπής της.

7

## Φροντίδα και καθαρισμός του αφυγραντήρα

**Αδειασμα του νερού**

Υπάρχουν 2 τρόποι να αδειάσετε το νερό από το δοχείο.

**1. Χρησιμοποιήστε το δοχείο**

- Όταν η μονάδα είναι κλειστή αλλά ο κάδος νερού είναι γεμάτος, θα ακουστεί ο ήχος «μπιπ» για 8 φορές, η αντίστοιχη ενδεικτική λυχνία θα αναβοσβήνει και η ψηφιακή οθόνη θα δείξει P2.
- Αν η μονάδα είναι ανοιχτή και ο κάδος είναι γεμάτος, ο συμπιεστής σταματάει να λειτουργεί και ο ανεμιστήρας σταματάει μετά από 30 δευτερόλεπτα, ώστε να στεγνώσει το στοιχείο της συσκευής. Θα ακουστεί ο ήχος «μπιπ» για 8 φορές, η αντίστοιχη ενδεικτική λυχνία θα αναβοσβήνει και η ψηφιακή οθόνη θα δείξει P2
- Τραβήξτε προσεκτικά το δοχείο κρατώντας το από την αριστερή και δεξιά λαβή. Μην ακουμπήσετε το δοχείο στο έδαφος διότι δεν είναι επίπεδο και θα χυθεί το νερό.
- Αδειάστε το νερό και επανατοποθετήστε το δοχείο σωστά στη θέση του για την ομαλή λειτουργία του αφυγραντήρα.
- Ο αφυγραντήρας θα επανέλθει σε λειτουργία όταν το δοχείο επανατοποθετηθεί στη σωστή του θέση.

**Σημείωση:**

- Μην αγγίζετε τα εσωτερικά μέρη της συσκευής, αφού έχετε αφαιρέσει το δοχείο. Μπορεί να προκαλέσετε βλάβη της συσκευής.
- Τοποθετήστε ομαλά το δοχείο πίσω στη συσκευή. Εάν το χτυπήσετε ή δεν το πιάσετε σωστά στη θέση του θα προκληθεί δυσλειτουργία της συσκευής.
- Όταν βγάλετε το δοχείο παρατηρήστε εάν υπάρχει νερό στη συσκευή, εάν ναι καθαρίστε το.

**Συνεχής αποστράγγιση**

Υπάρχει η δυνατότητα συνεχούς απορροής του νερού συνδέοντας έναν αγωγό αποστράγγισης (Φ13,5mm) (Δεν περιλαμβάνεται στην συσκευασία)

- Αφαιρέστε το επιστόμιο από το πίσω μέρος της μονάδας και φυλάξτε το σε ασφαλές μέρος.
- Τοποθετήστε τον αγωγό στην έξοδο αποστράγγισης στο πίσω μέρος της μονάδας, όπως φαίνεται στην Εικ.7.
- Βεβαιωθείτε πως δεν υπάρχει διαρροή νερού στο σημείο σύνδεσης.
- Οδηγήστε τον αγωγό αποστράγγισης είτε στην αποχέτευση είτε σε κάποιο άλλο κατάλληλο χώρο αποχέτευσης. Η αποχέτευση θα πρέπει να είναι χαμηλότερα από την έξοδο αποστράγγισης της μονάδας.
- Βεβαιωθείτε πως ο αγωγός αποστράγγισης έχει καθοδική κλίση για την ομαλή απορροή του νερού.
- Επιλέξτε το επιθυμητό ποσοστό υγρασίας και την ταχύτητα του ανεμιστήρα ώστε να ξεκινήσει.

**ΣΗΜΕΙΩΣΗ:** Όταν δε σκοπεύετε να χρησιμοποιήσετε την λειτουργία της συνεχούς αποστράγγισης, αποσυνδέστε τον αγωγό από την έξοδο και επανατοποθετήστε το επιστόμιο.

8

**1. Τραβήξτε ελαφρά το δοχείο**

Εικ.5

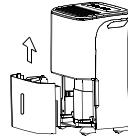
**2. Κρατήστε το δοχείο και από τις 2 λαβές και τραβήξτε το προσεκτικά από την μονάδα.**

Εικ.6

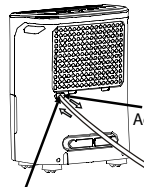
**3. Αδειάστε το νερό**

Εισάγετε τον αγωγό στην έξοδο αποστράγγισης

Αφαιρέστε το επιστόμιο

Εικ.7

## Φροντίδα και καθαρισμός του αφυγραντήρα

Πριν τον καθαρισμό απενεργοποιήστε τον αφυγραντήρα και αποσυνδέστε το φως από την πρίζα.

**1. Καθαρίστε το πλέγμα και το πλαίσιο**

- Χρησιμοποιήστε νερό και ουδέτερο απορρυπαντικό. Μην χρησιμοποιείτε λευκαντικά και στιλβωτικά.
- Μην ρίχνετε νερό στον αφυγραντήρα. Μπορεί να προκληθεί ηλεκτροπληξία, φθορά στη μόνωση ή σκουριά.
- Το πλέγμα εισόδου και εξόδου αέρα χρειάζονται συχνά καθαρισμό. Μπορείτε να τα καθαρίζετε είτε με ηλεκτρική σκούπα είτε με μαλακή βούρτσα.

**2. Καθαρισμός του δοχείου**

Το δοχείο πρέπει να καθαρίζεται σε τακτά χρονικά διαστήματα για την αποφυγή δημιουργίας μούχλας και βακτηριδίων. Καθαρίστε το δοχείο με καθαρό νερό και ουδέτερο απορρυπαντικό και ξεβγάλετε με καθαρό νερό. ΣΗΜΕΙΩΣΗ: Μην πλένετε το δοχείο σε πλυντήριο πιάτων. Μετά τον καθαρισμό επανατοποθετήστε το δοχείο στη σωστή θέση του.

**3. Καθαρισμός του φίλτρου αέρα**

Το φίλτρο αέρα θα πρέπει να καθαρίζεται τουλάχιστον κάθε 30 μέρες ή και συχνότερα αν είναι απαραίτητο. ΣΗΜΕΙΩΣΗ: ΜΗΝ ΧΡΗΣΙΜΟΠΟΙΕΙΤΕ ΓΙΑ ΤΟΝ ΚΑΘΑΡΙΣΜΟ ΤΟΥ ΦΙΛΤΡΟΥ ΠΛΥΝΤΗΡΙΟ

**Αφαίρεση φίλτρου**

- Αφαιρέστε το φίλτρο τραβώντας το προς τα πάνω και μετά προς τα έξω όπως φαίνεται στην Εικ.8.
- Καθαρίστε το φίλτρο με χλωράρο σαπουνοδιάλυμα και αφήστε το να στεγνώσει πριν το εγκαταστήσετε στη συσκευή. Μην το πλένετε σε πλυντήριο πιάτων.

**Επανατοποθέτησης φίλτρου:**

Εισάγετε στο φίλτρο στη μονάδα, όπως φαίνεται στην Εικ.11.

**ΠΡΟΣΟΧΗ:**

ΜΗΝ λειτουργείτε τη μονάδα χωρίς φίλτρο. Υπάρχει κίνδυνος να φράξει λόγω ακαθαρσιών και να μειωθεί η απόδοσή της.

**4. Όταν η μονάδα δεν θα χρησιμοποιηθεί για αρκετό χρονικό διάστημα**

- Αφού απενεργοποιήσετε τη μονάδα, περιμένετε 1 μέρα πριν αδειάσετε το δοχείο.
- Καθαρίστε το δοχείο, το φίλτρο και τα υπόλοιπα μέρη του αφυγραντήρα.
- Τυλίξτε το καλώδιο και δέστε το με ταινία. Καλύψτε τον αφυγραντήρα με μια πλαστική σακούλα.
- Αποθηκεύστε τον αφυγραντήρα σε όρθια θέση, σε ξηρό και επαρκώς αεριζόμενο χώρο.

9

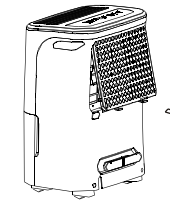

Εικ. 8

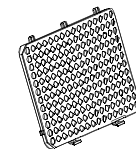

Εικ. 9

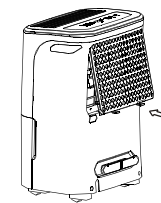

Εικ. 10

## ΑΝΤΙΜΕΤΩΠΙΣΗ ΠΡΟΒΛΗΜΑΤΩΝ

Πριν επικοινωνήσετε με τεχνικό προσωπικό, ελέγξτε τα παρακάτω

Πρόβλημα	Έλεγχος
	• μ • μ • μ
	• μ μ • μ • μ 5 C • μ
	• μ • μ
μ	• μ μ • μ
	• μ μ • μ μ
ES AS P1 2 μ	•

# Ενεργοποιήστε την εγγύησή σας...

## σε 5 απλά βήματα!



Σκανάρτε εδώ για τα έντυπα των εγγυήσεων

- 1** Συνδεθείτε στο site της Inventor στον ακόλουθο σύνδεσμο <http://www.inventoraircondition.gr/egiisi-inventor/>
- 2** Επιλέξτε τον τύπο του προϊόντος (κλιματιστικό ή συσκευή) για το οποίο θα ενεργοποιηθεί η εγγύηση
- 3** Επιλέξτε την εγγύηση που αντιστοιχεί στο προϊόν που έχετε στην κατοχή σας
- 4** Συμπληρώστε τα απαιτούμενα στοιχεία (κατόχου, εμπόρου και συσκευής) και πατήστε αποστολή
- 5** Θα λάβετε επιβεβαιωτικό μήνυμα στο e-mail σας για την ενεργοποίηση της εγγύησης

Για την υποβολή ηλεκτρονικών εγγυήσεων ηλεκτρολογήστε την παρακάτω διεύθυνση

**<http://www.inventoraircondition.gr/egiisi-inventor/>**

## OBSERVAȚIE SOCIALĂ

Când utilizați acest aparat în țările europene, este necesar să urmați indicațiile de mai jos:

**DEPOZITARE:** Nu depozitați acest produs ca deșeu municipal nesortat. Este necesară colectarea acestui deșeu separat pentru un tratament special.

Este interzisă depozitarea acestui dispozitiv împreună cu deșeurile casnice.

Există mai multe posibilități cu privire la depozitare:

- A) Municipality a înființat sisteme de colectare unde se pot depozita deșeurile electronice gratuit de către utilizator.
- B) Când achiziționați un produs nou, comerciantul va primi produsul vechi gratuit.
- C) Producătorul va primi gratuit de la utilizator aparatul vechi pentru depozitare.
- D) Având în vedere ca produsele vechi conțin resurse valoroase, pot fi vândute bucăți comercianților de metale.

Depozitarea deșeurilor în păduri și în natură va pune în pericol sănătatea atunci când substanțele periculoase se scurg în apa subterană și ajung în lanțul alimentar.



## CUPRINS

### MĂSURI DE SIGURANȚĂ

Avertisment .....	2
Atenție .....	2
Informații electrice .....	3
<b>BUTOANE DE CONTROL PE DEZUMIDIFICATOR</b>	
Butoane de control .....	4
Alte caracteristici .....	5
<b>IDENTIFICAREA PIESELOR</b>	
Identificarea pieselor .....	6
Poziționarea aparatului .....	7
<b>UTILIZAREA APARATULUI</b>	
Când se utilizează aparatul .....	7
Eliminarea apei colectate .....	8
<b>ÎNGRIJIRE ȘI ÎNTREȚINERE</b>	
Îngrijirea și curățarea dezumidicatorului .....	9
<b>DISFUNCȚII</b>	
Disfuncții .....	10

### Citiți acest manual

În interior, veți găsi multe sugestii utile cu privire la modul de utilizare al acestui aparat. Puteți economisi timp și bani pe durata de viață a aparatului dacă acordați atenție preventivă în îngrijirea aparatului. Veți găsi multe răspunsuri la problemele comune în graficul de sfaturi de depanare. Dacă examinați diagrama noastră de sfaturi de depanare în primul rând, nu va fi necesar să apelați la service.

### ATENȚIE

- Acest aparat poate fi folosit de copii cu vârsta de peste 8 ani și de către persoanele cu capacități fizice și mentale reduse sau cu lipsă de experiență sau cunoștințe dacă sunt supravegheați sau li se acordă instruire cu privire la folosirea aparatului în siguranță și dacă înțeleg pericolele pe care le implică. Copiii nu trebuie să se joace cu aparatul. Menținerea uzuală și curățarea nu se vor face de către copii fără supraveghere. (aplicabil pentru țările europene)
- Acest aparat nu este destinat utilizării de către persoane (inclusiv copii) cu capacități fizice reduse, senzoriale sau mentale, sau lipsite de experiență și cunoștințe, cu excepția cazului în care acestea au fost supravegheate și instruite cu privire la utilizarea aparatului de către o persoană responsabilă pentru siguranța lor. (aplicabil pentru alte țări cu excepția țărilor europene)
- Copiii trebuie supravegheați pentru a vă asigura că nu se joacă cu acest aparat.
- În cazul în care cablul de alimentare este deteriorat, acesta trebuie înlocuit de către producător, agentul de service sau persoane calificate, în scopul de a evita un pericol.
- Aparatul va fi instalat în conformitate cu reglementările naționale privind cablarea.
- Acest aparat cu radiator electric va avea cel puțin 1 metru distanță față de materiale combustibile.
- Contactați un tehnician de service autorizat pentru reparația sau întreținerea acestui aparat.

## MĂSURI DE SIGURANȚĂ

Pentru a preveni rănirea utilizatorului sau a altor persoane și prejudicierea proprietății, trebuie respectate următoarele instrucțiuni. Utilizarea incorectă ca urmare a nerespectării instrucțiunilor poate provoca rănire sau distrugere

■ Gravitatea este evaluat în baza următoarelor indicații

	<b>AVERTISMENT</b>	Acest simbol indică riscul de deces sau rănire gravă
	<b>ATENȚIE</b>	Acest simbol indică riscul de rănire sau distrugere a proprietății

■ Semni ca și simbolurile utilizate în acest manual este indicat mai jos

	Nu procedați niciodată așa
	Acționați întotdeauna așa

### AVERTISMENT

- |  |   |   |
|--|---|---|
| <p> Nu depășiți capacitatea prizei de curent electric sau a dispozitivului de legătură</p> <ul style="list-style-type: none"> <li>● În caz contrar, există risc de șoc electric sau incendiu datorită generării de căldură în exces</li> </ul> | <p> Nu porniți și nu opriți unitatea prin pornirea sau oprirea curentului</p> <ul style="list-style-type: none"> <li>● Există risc de șoc electric sau incendiu datorită generării de căldură în exces</li> </ul> | <p> Nu deteriorați și nu utilizați un cablu electric necorespunzător</p> <ul style="list-style-type: none"> <li>● Există risc de șoc electric sau incendiu</li> </ul> |
| <p> Nu modificați lungimea cablului electric și nu utilizați prize pentru alte aparate</p> <ul style="list-style-type: none"> <li>● Există risc de șoc electric sau incendiu datorită generării de căldură în exces</li> </ul>                 | <p> Nu introduceți și nu trageți cablul cu mâinile umede.</p> <ul style="list-style-type: none"> <li>● Există risc de șoc electric</li> </ul>   | <p> Nu așezați unitatea lângă o sursă de căldură</p> <ul style="list-style-type: none"> <li>● Piese din plastic se pot topi și pot provoca un incendiu.</li> </ul>    |
| <p> Deconectați de la sursa de curent dacă generează sunete ciudate, mirosuri sau fum</p> <ul style="list-style-type: none"> <li>● Există risc de incendiu sau electrocutare</li> </ul>  | <p> Nu se recomandă să încercați să desfaceți sau să reparați unitatea personal</p> <ul style="list-style-type: none"> <li>● Există risc de defectare a aparatului sau șoc electric</li> </ul>                    | <p> Înainte de a curăța, opriți curentul și deconectați unitatea</p> <ul style="list-style-type: none"> <li>● Există risc de șoc electric sau rănire</li> </ul>       |
| <p> Nu utilizați aparatul în apropiere de gaz sau combustibili inflamabili cum ar fi gazolină, benzen, diluant etc</p> <ul style="list-style-type: none"> <li>● Există risc de explozie sau incendiu</li> </ul>                                | <p> Nu consumați și nu utilizați apa scursă din aerul condiționat.</p> <ul style="list-style-type: none"> <li>● Conține contaminanți și vă puteți îmbolnăvi</li> </ul>  | <p> Nu deschideți unitatea în timpul funcționării</p> <ul style="list-style-type: none"> <li>● Există risc de șoc electric</li> </ul>                                 |

### ATENȚIE

- |  |  |  |
|--|--|--|
| <p> Când utilizați în cabinete sau în alte spații mici, asigurați-vă că lăsați ușile deschise</p> <ul style="list-style-type: none"> <li>● Lipsa aerisirii poate provoca supraîncălzire și incendiu</li> </ul> | <p> Nu așezați în locuri în care unitatea poate fi împrăștiată cu apă</p> <ul style="list-style-type: none"> <li>● Apa poate pătrunde în unitate și afecta izolarea. Poate cauza șoc electric sau incendiu.</li> </ul> | <p> Așezați unitatea la înălțime, pe o secțiune rigidă pe podea</p> <ul style="list-style-type: none"> <li>● Dacă unitatea cade, apa se poate împrăști și prejudicia bunurile sau provoca șoc electric sau incendiu</li> </ul> |
|--|--|--|

2

## MĂSURI DE SIGURANȚĂ

### ATENȚIE

- |   |  |  |
|---|--|--|
| <p> Nu acoperiți prizele sau orificiile de evacuare cu cărpe sau prosoape</p> <ul style="list-style-type: none"> <li>● Lipsa aerului poate conduce la supraîncălzire și incendiu</li> </ul>   | <p> Atenție când utilizați unitatea într-o cameră în care se află următoarele persoane:</p> <ul style="list-style-type: none"> <li>● Bebeluși, copii, persoane mai în vârstă și persoane care nu sunt sensibile la umiditate</li> </ul>      | <p> Nu utilizați în zone în care se folosesc substanțe chimice.</p> <ul style="list-style-type: none"> <li>● Unitatea va fi afectată de substanțele chimice și de solvenții dizolvați în aer</li> </ul>                          |
| <p> Când curățați unitatea, deconectați și opriți întrerupătorul</p> <ul style="list-style-type: none"> <li>● Nu curățați unitatea când este alimentată cu curent pentru că se poate provoca un incendiu și electrocutare, puteți fi rănit</li> </ul> | <p> Nu așezați obiecte grele pe cablu și verificați cablul pentru a nu fi strangulat</p> <ul style="list-style-type: none"> <li>● Există risc de incendiu sau șoc electric</li> </ul>  | <p> Nu vă urcați și nu vă așezați pe unitate</p> <ul style="list-style-type: none"> <li>● Există risc de rănire în cazul în care cădeți sau dacă unitatea cade</li> </ul>  |
| <p> Introduceți întotdeauna filtrele în siguranță. Curățați filtrul o dată la două săptămâni</p> <ul style="list-style-type: none"> <li>● Funcționarea fără filtre poate provoca o disfuncție</li> </ul>  | <p> Dacă apa pătrunde în unitate, opriți unitatea și deconectați de la sursa de curent, contactați un tehnician calificat</p> <ul style="list-style-type: none"> <li>● Există riscul de defectare a unității sau risc de accident</li> </ul> | <p> Nu așezați flori, vase sau alte recipiente cu apă pe unitate</p> <ul style="list-style-type: none"> <li>● Apa poate pătrunde în interiorul unității, provocând defectarea izolației și șoc electric sau incendiu.</li> </ul> |

### Informații electrice

- Plăcuța cu numele producătorului se află pe panoul anterior al unității și conține date electrice precum și alte informații tehnice specifice acestei unități
- Asigurați-vă că aerul condiționat este împământat corespunzător. Pentru a reduce riscurile de electrocutare și incendiu, este importantă împământarea corespunzătoare.
- Aerul condiționat trebuie conectat la o priză de perete împământată corespunzător. Dacă prizele de perete care intenționează să o utilizați nu este împământată corespunzător sau protejată prin amorsă cu întârziere sau întrerupător, apelați la un electrician calificat pentru a instala prizele adecvate.
- Asigurați-vă că prizele sunt accesibile după instalarea unității.
- Nu folosiți prelungitoare sau fișe intermediare cu această unitate. Însă, dacă este necesar să utilizați un prelungitor, folosiți doar prelungitor aprobat pentru „aer condiționat” (disponibil în majoritatea magazinelor locale hardware).
- Pentru a evita posibilitatea unei prejudicieri personale, deconectați întotdeauna unitatea de la sursa de alimentare înainte de instalare și/sau reparare.

3

## BUTOANE DE CONTROL PE DEZUMIDIFICATOR

NOTĂ: Panoul de control al unității poate fi ușor diferit, în funcție de model.

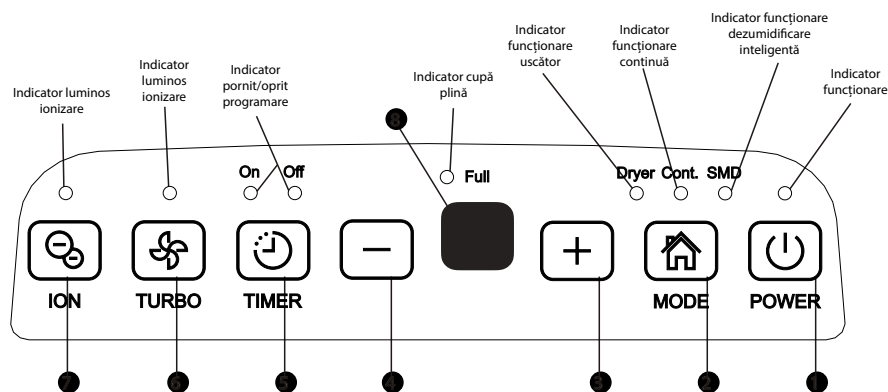

Fig.1

### Butoane de control

La apăsarea tastelor pentru schimbarea modului de operare, se va auzi un sunet ce indică faptul ca modul de funcționare se schimbă.

#### ● Butonul de pornire

Se apasă pentru a porni sau opri aparatul.  
NOTĂ: Când compresorul pornește sau se oprește se va auzi un zgomot, lucru absolut normal

#### ● Butonul Mod de funcționare

Se apasă pentru a selecta modul de operare dorit și anume dezumidificare, uscare, dezumidificare continuă și inteligentă.  
NOTĂ: Uscarea și dezumidificarea inteligentă sunt opționale.

#### ● ● (+/-) Tastele plus și minus (sus/jos)

##### ● Controlul umidității

Nivelul umidității poate fi setat între 35% și 85% cu trepte egale de 5%.

Pentru un aer mai uscat, apăsați tasta minus și setați cea mai scăzută valoare.

Pentru un aer mai umed, apăsați tasta plus și setați cea mai mare valoare.

NOTĂ: Uscarea și dezumidificarea inteligentă sunt opționale.

##### ● Controlul programării timpului de funcționare

Folosiți tastele plus și minus pentru a seta auto-pornirea sau auto-oprirea aparatului pentru un timp cuprins între 0 și 24 de ore

#### ● Tasta TIMER (programarea timpului)

Apăsați pentru a activa funcția, apoi setați timpul dorit folosind tastele ⊕ și ⊖.

#### ● Tasta Turbo

Controlează viteza ventilatorului. Apăsați pentru a selecta viteză maximă (high). Când nivelul umidității este redus și se dorește o funcționare mai silențioasă, setați pe normal

#### ● Tasta ION (ionizare - opțional)

Apăsați pentru a activa funcția de ionizare. Ionii elimină particulele de chimicale și praf. Pentru a opri, apăsați din nou pe această tastă.

#### ● Afășajul

Arată umiditatea setată cuprinsă între 35% și 85% sau modul auto de pornire sau oprire a aparatului în momentul setării, apoi arată nivelul actual al umidității din cameră (cu o eroare de +/- 5%) cuprins între 30% și 90%.

#### ● Coduri de eroare și de protecție

**AS** - Eroare senzor de umiditate - Scoateți aparatul din priză și reconectați-l. Dacă eroarea reapare, contactați service-ul.

**ES** - Eroare senzor de temperatură - Scoateți aparatul din priză și reconectați-l. Dacă eroarea reapare, contactați service-ul.

### Alte funcții

**Indicator cupă plină**  
Acesta este aprins atunci când cupa trebuie golită sau atunci când este înlăturată sau nu este în poziția corectă.

#### Oprirea automată

Aparatul se oprește singur atunci când cupa este plină, înlăturată sau nu este în poziția corectă. Atunci când este atins nivelul de umiditate setat, aparatul se oprește automat. La anumite modele, ventilatorul va continua să funcționeze.

#### Degivrare automată

Atunci când se formează gheață pe condensator, compresorul se va opri iar ventilatorul va funcționa până când gheața va fi înlăturată.  
NOTĂ: În timpul acestei operațiuni, se pot auzi zgomote ciudate, lucru absolut normal.

#### Așteptați 3 minute înainte de a reporni funcționarea

Atunci când aparatul se oprește, nu poate fi repornit decât după trecerea a 3 minute. În acest fel aparatul este protejat. Funcționarea va fi reluată automat după 3 minute.

#### Dezumidificare inteligentă (opțional)

Atunci când este activată această funcție, aparatul va controla automat umiditatea din cameră la un nivel confortabil cuprins între 45%-55% potrivit temperaturii din cameră. Funcția de setare a umidității va fi inactivă.

## BUTOANE DE CONTROL PE DEZUMIDIFICATOR

**P1** - Aparatul a intrat în faza de dezghețare automată - după finalizarea dezghețării, de pe ecran va dispărea P1.

**P2** - Cupa este plină cu apă sau nu este în poziția corectă - Goliți cupa și așezați-o în poziția corectă.

**E3** - Eroare de funcționare - Scoateți aparatul din priză și reconectați-l. Dacă eroarea reapare, contactați service-ul.

**EC** - Detectare scurgere agent frigorific - Cu această nouă tehnologie, pe afășaj va apărea EC atunci când aparatul va detecta scurgeri de agent frigorific, contactați service-ul.

### Auto-Restart

În cazul în care se oprește sau se întrerupe curentul, aparatul va reporni automat cu setările utilizate ultima dată după restabilirea curentului.

### Setarea timpului

- Când aparatul funcționează, mai întâi apăsați tasta TIMER iar indicatorul TIMER OFF se va aprinde. Arata faptul că programarea pentru a opri aparatul a fost inițiată. La următoarea apăsare indicatorul pentru TIMER ON se va aprinde. Arată faptul că programarea pentru a auto-porni a fost inițiată.
- Când aparatul este oprit, mai întâi apăsați tasta TIMER iar indicatorul TIMER ON se va aprinde. Arata faptul că programarea pentru a auto-porni aparatul a fost inițiată. La următoarea apăsare indicatorul pentru TIMER OFF se va aprinde. Arată faptul că programarea pentru a oprirea automată a fost inițiată.
- Apăsați sau țineți apăsat butonul plus sau minus iar timpul va modifica cu 0.5 ore până la 10 ore, apoi din ora în ora până la 24. Funcția va funcționa până când timpul setat se va atinge.
- Timpul setat va fi afășat timp de 5 secunde, iar apoi pe ecran se va arată umiditatea setată.
- Atunci când este setată atât pornirea cât și oprirea automată ambele indicatoare vor fi aprinse și ambele sunt programate.
- Pornirea sau oprirea sau se modifică timpul setat la 0.0 se va anula funcția de pornire sau oprire.
- Când pe ecran apare P2, funcția de pornire sau oprire se va auto-anula.



## IDENTIFICAREA PIESELOR

### Funcția uscare (opțional)

Aparatul va efectua dezumidificare maximă atunci când este pornită funcția de uscare. Viteza ventilatorului este pe viteza maximă. Controlul umidității este efectuat automat în funcție de umiditatea din cameră. După 10 ore de funcționare funcția se va dezactiva automat.

#### NOTE:

- Funcția de uscare trebuie să se utilizeze într-o cameră cu ușile și ferestrele închise.
- Pentru un efect maxim, hainele trebuie să fie bine stoarse.
- Asigurați fluxul de aer să fie îndreptat înspre hainele ude (vezi fig. A)
- Pentru haine groase și nestoarse efectul nu va fi foarte eficient.

#### ⚠ ATENȚIE

- Nu acoperiți gurile de aer cu haine. Aparatul se poate încălzi excesiv, se poate defecta și poate lua foc.
- Nu puneți hainele deasupra aparatului și evitați să patrundă apă în aparat. Poate provoca șocuri electrice și defectarea imediată a aparatului.

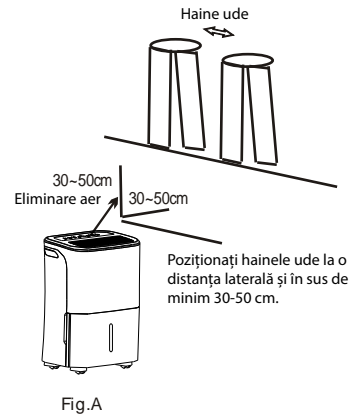

Fig.A

### Identificarea pieselor

#### FAȚĂ

- 1 Panou control
- 2 Mânere (ambele părți)
- 3 Grilaj de eliminare a aerului
- 4 Cupă pentru apă
- 5 Fereastră nivel apă

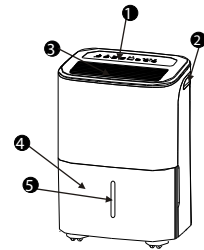

Fig.2

#### SPATE

- 1 Evacuare furtun scurgere
- 2 Roți
- 3 Cablu de alimentare și ștecher
- 4 Grilaj admisie aer
- 5 Filtru de aer (în spatele grilei de admisie aer)
- 6 Cârlig cablu de alimentare (Utilizat doar atunci când se depozitează aparatul)

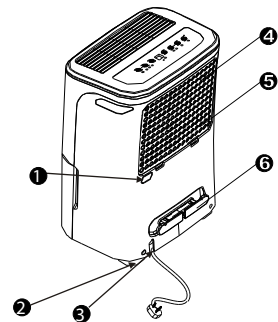

Fig.3

## IDENTIFICAREA PIESELOR

### Așezarea aparatului

Un dezumidificator care funcționează la subsol va avea un efect redus sau nu va avea niciun efect de uscare a unui spațiu de depozitare închis adiacent cum ar fi un cabinet decât dacă aerul circulă corespunzător în și din spațiul respectiv.

- Nu folosiți în exterior
- Acest dezumidificator este destinat doar utilizărilor rezidențiale în interior. Acest dezumidificator nu se va utiliza în scop comercial sau industrial.
- Așezați dezumidificatorul pe o podea netedă și nivelată, care poate susține aparatul cu cupa de apă plină.
- Lăsați cel puțin 20 cm spațiu pentru aer în toate direcțiile aparatului pentru o bună circulație a aerului.
- Așezați aparatul într-o zonă în care temperatura nu va scădea sub 50C (410F). Rolele pot fi acoperite cu gheață la o temperatură sub 50C (410F), ceea ce poate afecta funcționarea.
- Așezați aparatul departe de uscătorul de haine, încălzitor sau radiator.
- Folosiți aparatul pentru a împiedica umezeala să afecteze cărțile sau lucrurile de valoare.
- Folosiți dezumidificatorul la subsol pentru a împiedica prejudiciile cauzate de umezeală.
- Dezumidificatorul trebuie să fie utilizat într-un spațiu închis pentru a funcționa la eficiență maximă.
- Închideți toate ușile, ferestrele și toate celelalte deschideri exterioare din cameră.

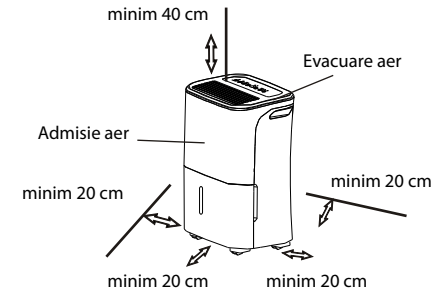

Fig.4a

Roțile (se instalează în cele patru puncte de la baza aparatului)

- Roțile se pot învârti liber în orice direcție se dorește.
- Nu forțați să mutați aparatul peste covor și nici cu rezervorul plin cu apă (aparatul se poate răsturna și vărsa apa)

### Când se utilizează aparatul

- Când se utilizează pentru prima dată dezumidificatorul, utilizați aparatul continuu 24 de ore.
- Acest aparat este creat pentru a funcționa într-un mediu de lucru cuprins între 5°C și 41°C.
- Dacă aparatul a fost oprit și trebuie să fie pornit din nou imediat, lăsați aproximativ trei minute pentru reluarea unei funcționări corecte.
- Nu conectați dezumidificatorul la o priză multiplă care este utilizată și pentru alte aparate electrice.
- Alegeți o locație adecvată, asigurându-vă că aveți acces ușor la priza electrică.
- Conectați aparatul la o priză electrică cu împământare (220V 50Hz).
- Asigurați-vă că este corect montată cupa de apă, în caz contrar, aparatul nu va funcționa corect.

NOTĂ: Când nivelul apei din cupă ajunge la un anumit nivel, evitați mutarea aparatului pentru a evita răsturnarea aparatului.

**Eliminarea apei colectate**

- Când aparatul este oprit și cupa este plină, aparatul va emite de 8 ori un semnal sonor și indicatorul luminos Full se aprinde intermitent - pe ecran apare P2.
- Când aparatul este pornit, iar cupa este plină, compresorul se va opri iar ventilatorul se va opri după 30 de secunde pentru a elimina condensul, aparatul va emite de 8 ori un semnal sonor și indicatorul luminos Full se aprinde intermitent - pe ecran apare P2.
- Scoateți ușor cupa. Prindeți mânerul cupei în siguranță și scoateți cu atenție pentru a nu vărsa apa. Nu puneți cupa pe podea pentru că fundul cupei nu este plat. În caz contrar, cupa va cădea, iar apa se va împrăști.
- Aruncați apa și înlocuiți cupa. Cupa trebuie să fie fixată și așezată în siguranță pentru ca dezumidificatorul să funcționeze.
- Aparatul va reporni atunci când cupa este așezată în poziția corectă.

**NOTE:**

- Când scoateți cupa, nu atingeți părțile interioare ale aparatului.
- Altfel ați putea prejudicia produsul.
- Asigurați-vă că împingeți cupa ușor în aparat. Lovirea cupei de ceva sau neîmpingerea sa în siguranță poate cauza disfuncția aparatului.
- Atunci când scoateți cupa, stergeți apa și din interiorul aparatului.

**2. Golire continuă**

Apa poate fi goliată în mod automat într-o gură de scurgere prin atașarea unui furtun de apă (nu sunt incluse).

- Scoateți dopul din spatele aparatului. Atașați un furtun de evacuare (ID = 13,5 mm) și întreptați-l spre scurgerea din pardoseală sau către o instalație de drenaj adecvat (vezi Fig. 7).
- Asigurați-vă că furtunul este securizat astfel încât să nu existe scurgeri.
- Îndreptați furtunul spre scurgere, asigurându-vă că nu este îndoit astfel încât apa să nu fie împiedicată să curgă din furtun.
- Puneți capătul furtunului în scurgere și asigurați-vă că capatul furtunului este la nivel sau în jos pentru a permite fluxul de apă. Să nu îl poziționați în sus.
- Selectați valoarea dorită de umiditate și viteza ventilatorului pentru a începe.

NOTĂ: Dacă funcția de evacuare continuă nu este utilizat, scoateți furtunul de evacuare de la priză.

1. Trageți cupa afară puțin.



Fig.5

2. Prindeți mânerul cupei cu putere și trageți afară din aparat.

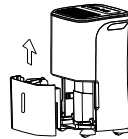
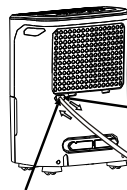

Fig.6

3. Scurgeți apa



Atașați furtunul la orificiul furtunului de scurgere

Scoateți dopul de cauciuc

Fig.7

**Eliminarea apei colectate**

**Îngrijirea și întreținerea dezumidificatorului**

Oprii dezumidificatorul și scoateți din priză înainte de curățare.

**1. Curățați grilajul și cutia**

- Folosiți apă și un detergent fin. Nu folosiți decolorant sau abrazive.
- Nu vărsați apă direct pe unitatea principală. În caz contrar, există risc de șoc electric, prejudiciere a izolației sau ruginire a aparatului.
- Orificiul de admisie a aerului și grilajele de evacuare se murdăresc ușor, așadar, folosiți un atașament de aspirator sau o perie pentru a curăța.

**2. Curățați cupa**

La câteva săptămâni, curățați cupa pentru a preveni sporirea mușcăiului, a ciupercilor și a bacteriilor. Umpleți parțial cupa cu apă curată și adăugați puțin detergent fin. Agitați puțin cupa, scurgeți și spălați.

NOTĂ: Nu folosiți o mașină de spălat vase pentru a curăța cupa. După curățare, cupa trebuie așezată la loc și fixată în siguranță pentru funcționarea dezumidificatorului.

**3. Curățați filtrul de aer**

Filtrul de aer din spatele grilajului frontal trebuie verificat și curățat cel puțin o dată la 30 de zile sau mai mult dacă este necesar.

NOTĂ: NU CLĂTIȚI ȘI NU PUNEȚI FILTRUL ÎNTR-O MAȘINĂ AUTOMATĂ DE SPĂLAT VASE.

**Pentru a înlătura:**

- Ridicați grilajul de pe filtru apoi scoateți-l așa cum se indică în Fig. 8.
- Curățați filtrul cu apă caldă cu săpun. Clătiți și lăsați filtrul să se usuce înainte de a-l înlocui. Nu curățați filtrul într-o mașină de spălat vase.

**Pentru a atașa:**

- Introduceți filtrul de aer în aparat de jos în sus. Vezi Fig. 10.

**ATENȚIE:**

NU utilizați dezumidificatorul fără filtru pentru că mizeria și fibrele îl vor înfunda și îi vor reduce performanța.

**4. Când nu folosiți aparatul perioade de timp îndelungate**

- După ce opriți aparatul, așteptați o zi înainte de a goli rezervorul.
- Curățați unitatea principală, cupa, nebulizatorul ultrasonic și filtrul de aer.
- Acoperiți aparatul cu o sacoșă din plastic
- Așezați aparatul vertical într-un loc uscat și bine ventilat.

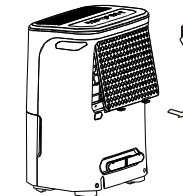

Fig. 8

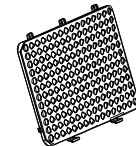

Fig. 9

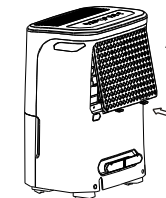

Fig. 10

## SFATURI PENTRU DEPANARE

Înainte de a apela service-ul, consultați tabelul de mai jos pentru a vedea ce puteți rezolva singuri.

Problem	Ce trebuie verificat
Aparatul nu pornește	<ul style="list-style-type: none"><li>● Asigurați-vă că mufa dezumidicatorului este introdusă bine în priză.</li><li>● Verificați siguranțele / cutia întrerupătorului de circuit.</li><li>● Dezumidicatorul a atins nivelul său presetat sau recipientul cu apă este plin.</li><li>● Recipientul nu este așezat în poziția corectă.</li></ul>
Dezumidicatorul nu usucă aerul așa cum ar trebui	<ul style="list-style-type: none"><li>● Nu a fost permis destul timp pentru îndepărtarea umezelii.</li><li>● Asigurați-vă că nu există perdele, jaluzele sau mobilă care să blocheze fața și spatele dezumidicatorului.</li><li>● Setarea de umiditate poate să nu fie setată îndeajuns de jos.</li><li>● Verificați că toate ușile, ferestrele și alte deschizături sunt bine închise.</li><li>● Temperatura camerei este prea mică, sub 5°C (41°F).</li><li>● Există un radiator cu gaz lampant sau altceva ce emană vapori de apă în încăperea.</li></ul>
Aparatul scoate un zgomot mare când funcționează	<ul style="list-style-type: none"><li>● Filtrul de aer este înfundat.</li><li>● Aparatul este înclinat și nu drept, în picioare, cum ar trebui.</li><li>● Suprafața podelei nu este dreaptă</li></ul>
Se formează gheață pe bobine	<ul style="list-style-type: none"><li>● Aceasta este normală. Aparatul are funcție automată de dezghețare.</li></ul>
Apare apă pe podea	<ul style="list-style-type: none"><li>● Furtunul de legătură este slăbit, sau legătura furtunului este slăbită.</li><li>● Vreți să folosiți recipientul pentru golirea apei dar ați uitat dopul de cauciuc din spate detașat.</li></ul>
ES, AS, P1 sau P2 se aprinde pe Display.	<ul style="list-style-type: none"><li>● Acestea sunt coduri de protecție și de eroare. Vezi secțiunea BUTOANE DE CONTROL PE DEZUMIDIFICATOR.</li></ul>

